

# Bi-directional Converter Charger

## Bi1248-1200

### User Manual

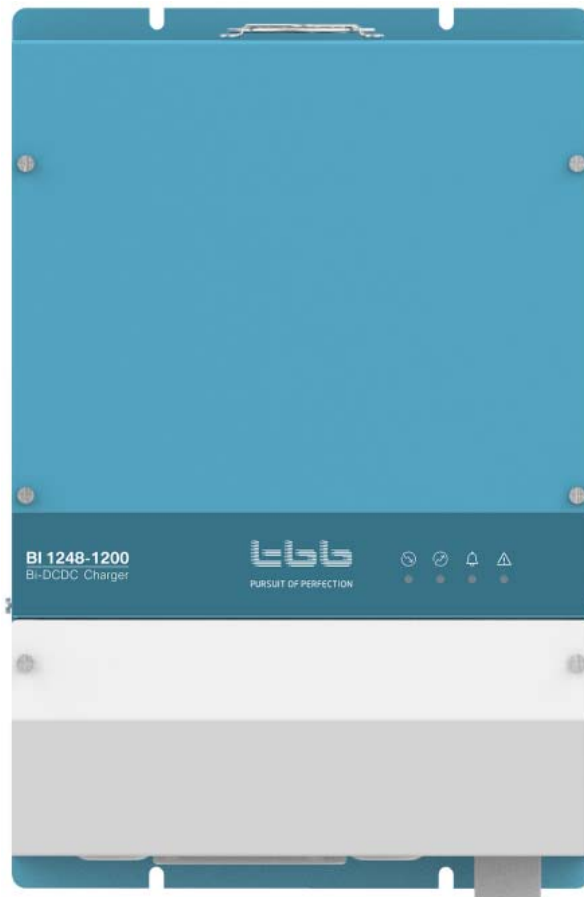

**Version: A1.0**

**Date: Dec. 2019**

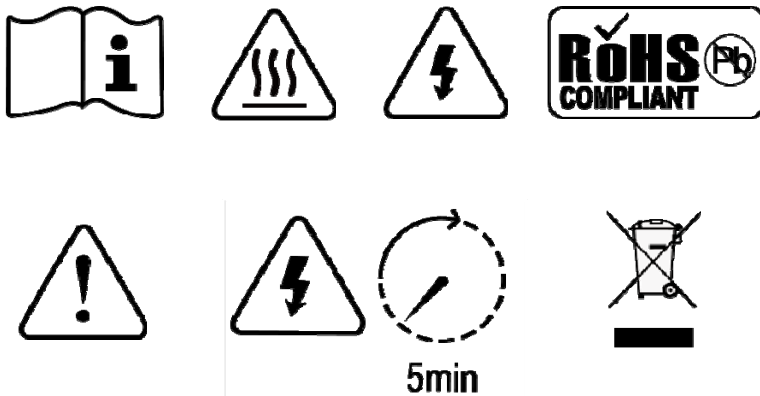

**WARNING : FIRE HAZARD**

**SUITABLE FOR MOUNTING ON CONCRETE OR OTHER  
NON- COMBUS TABLE SURFACE ONLY**

**CAUTION : THE DC AND AC BREAKER MUST HAVE BEEN  
TURNED OFF BEFORE SERVICING**

**MADE IN CHINA**

## Disclaimer

Unless specially agreed in writing, TBB Power Co., Ltd.

- Take no warranty as to the accuracy, sufficiency of suitability of any technical or other information provided in this manual or other documentation.
- Assumes no responsibility or liability for loss or damage, whether direct, indirect, consequential or incidental, which might arise out of the use of such information
- TBB offer standard warranty with its products, taking no responsibility for direct or indirect loss due to equipment failure.

## About this Manual

This manual describes our product features and provides procedure of installations. This manual is for anyone intending to install our equipment.

## General Instruction

Thanks for choosing our products and this manual were suitable for DC/DC Bi-directional Converter Bi1248-1200.

This chapter contains important safety and operation instructions. Read and keep this User Guide well for later reference.

The DC/DC Bi-directional Converter Bi1248-1200 needs to be installed by professionals and please pay attention to the following points prior to installation:

- 1> Please check the input voltage or voltage of battery is same to the nominal input voltage of this unit.
- 2> Please connect positive terminal “+” of battery to “+” input of this unit.
- 3> Please connect negative terminal “-” of battery to “-” input of this unit.
- 4> Please use the shortest cable to connect and ensure the secure connection.
- 5> While connecting, please secure the connection and avoid short cut between positive terminal and negative terminal of battery, which will cause damage of battery.
- 6> This unit will have high voltage inside. Only authorized electrician can open the case.
- 7> This unit WAS NOT designed to use in any life retaining equipment.

# Index

1. General Safety Instruction .....	1
1.1 Safety Instruction .....	1
1.2 General Precaution .....	1
1.3 Precaution regarding battery operation .....	1
2. Description of main Function .....	2
2.1 Product introduction .....	错误! 未定义书签。2
2.2 Product principle .....	2
2.3 Features .....	3
2.4 Naming rule .....	4
3. Structure .....	4
3.1 Product drawing and dimension drawing .....	4
4. Pre-installation Configuration .....	5
4.1 Unpacking inspection .....	6
4.2 Installation requirements .....	5
4.3 Cable preparation .....	5
5. Installation .....	5
5.1 Installation recommendations and operations .....	6
5.1.1 Installation drawing .....	7
5.2 Wiring recommendation .....	8
5.2.1 Wiring diagram .....	9
5.3 COM terminal definition .....	10
6. Users Instructions .....	11
6.1 Power on check and instructions .....	11
6.2 Indicator definition .....	12
6.3 DIP switch definition .....	8
6.4 Module working conditions .....	12
6.5 Service battery charging curve .....	13
6.6 Operating temperature derating curve .....	14
7. Technical Data Sheet .....	15

# 1. General Safety Instruction

## 1.1 Safety Instruction

As dangerous voltages and high temperature exist within Bi1248-1200, only qualified and authorized maintenance personnel are permitted to open and repair it. Please make sure Bi1248-1200 is turned off before open and repair it.

This manual contains information concerning the installation and operation of Bi1248-1200. All relevant parts of the manual should be read prior to commencing the installation. Please follow the local stipulation meantime.

Any operation against safety requirement or against design, manufacture, safety standard, and are out of the manufacturer warranty.

## 1.2 General Precaution

Do not expose to dust, rain, snow or liquids of any type, it is designed for indoor use. DO NOT block off ventilation, otherwise Bi1248-1200 would be overheating.

To avoid fire and electric shock, make sure all cables selected with right gauge and being connected well. Smaller diameter and broken cable are not allowed to use.

Please do not put any inflammable goods near to Bi1248-1200.

Never place Bi1248-1200 directly above batteries, gases from a battery will corrode and damage it.

Do not place battery over Bi1248-1200.

## 1.3 Precaution regarding battery operation

Use plenty of fresh water to clean in case battery acid contacts skin, clothing, or eyes and consult with doctor as soon as possible.

The battery may generate flammable gas during charging. NEVER smoke or allow a spark or flame in vicinity of a battery.

Do not put the metal tool on the battery; spark and short circuit might lead to explosion.

REMOVE all personal metal items such as rings, bracelets, necklaces, and watches while working with batteries. Batteries can cause short-circuit current high enough to make metal melt, and could cause severe burns.

## 2. Description of main Function

### 2.1 General Description

Bi1248-1200 is a bi-directional converter charger for vehicles or boat which has dual battery system installed. It was designed to charge 48Vdc auxiliary battery on a 12Vdc chassis. Due to its bi-directional design, the 12Vdc load can be powered as it used to be.

Upon driving or engine on, through this device, the output of 12Vdc alternator can be used to charge 48Vdc auxiliary battery and meantime power the 12Vdc loads. Upon engine stop, this device will convert 48Vdc into 12Vdc, powering all 12Vdc loads.

- **Traditional alternator:** When the device detects that the starter battery voltage is higher than 13.3V, it will takes power from alternator to charges the 48V auxiliary battery with a maximum charging current of 25A. Upon the starter battery voltage is lower than 12.8V, this device will stop working.
- **Smart alternator / Euro 6 :** Through dip switch, this device can be set to smart alternator mode. After choosing this mode, IGN signal or similar signal wire must be connected. Combined with IGN signal and voltage, the device will decide the charging.
  - ◆ Charging : IGN active and starter battery voltage is higher than 12.2V
  - ◆ Stop charging: IGN active and the starter battery voltage is lower than 11.6V.

### 2.2 Product principle

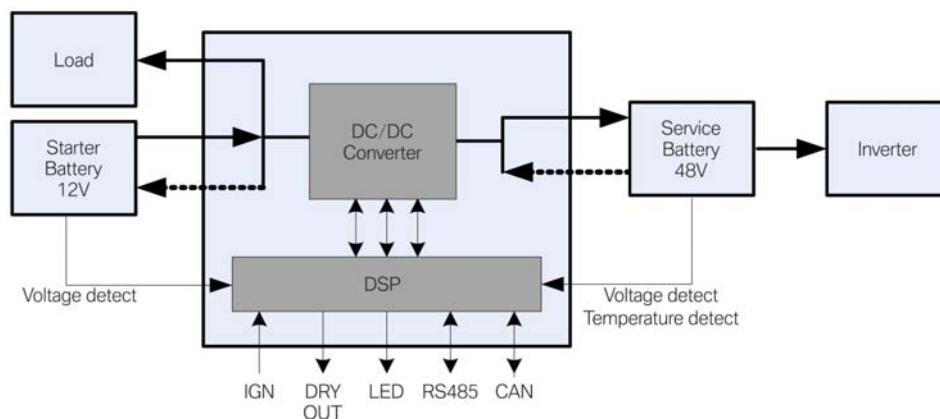

The Bi1248-1200 adopts a non-isolated conversion topology with high efficiency up to 94% or above. Adopting DSP control, complex control algorithms can be achieved and meantime featuring high control precision and fast response speed.

After the starter battery and the service battery are connected to the unit, as well as the IGN signal, the unit can independently implement the charge and discharge and maintain the reliable operation. With built in isolated RS485 and CAN communication, it can be used for any system with monitoring and control requirement.

## 2.3 Features

- High Power in-vehicle charging, max 1.2KWH can be charged per hour.
- DSP control with fast and sophisticated algorithm
- Non-isolation design with max efficiency 94%
- Alternator Input range 11.6-16Vdc, standing up to 35Vdc
- Can be used for Euro6 with smart alternator
- Multiple battery chemical can be chose including lithium battery
- TBB premium II multiple stages charging algorithm
- Built in automatic temperature and voltage compensated charging
- Thermal controlled fan cooling
- With built in RS485 and CAN capability
- Dry contact output, capacity of 250Vac/28Vdc 5A
- Dry contact input, for external control to power off the device
- Complete protection against output short circuit, output over current, over/low voltage, over temperature and output reverse polarity

### 3. Structure

#### 3.1 Dimension

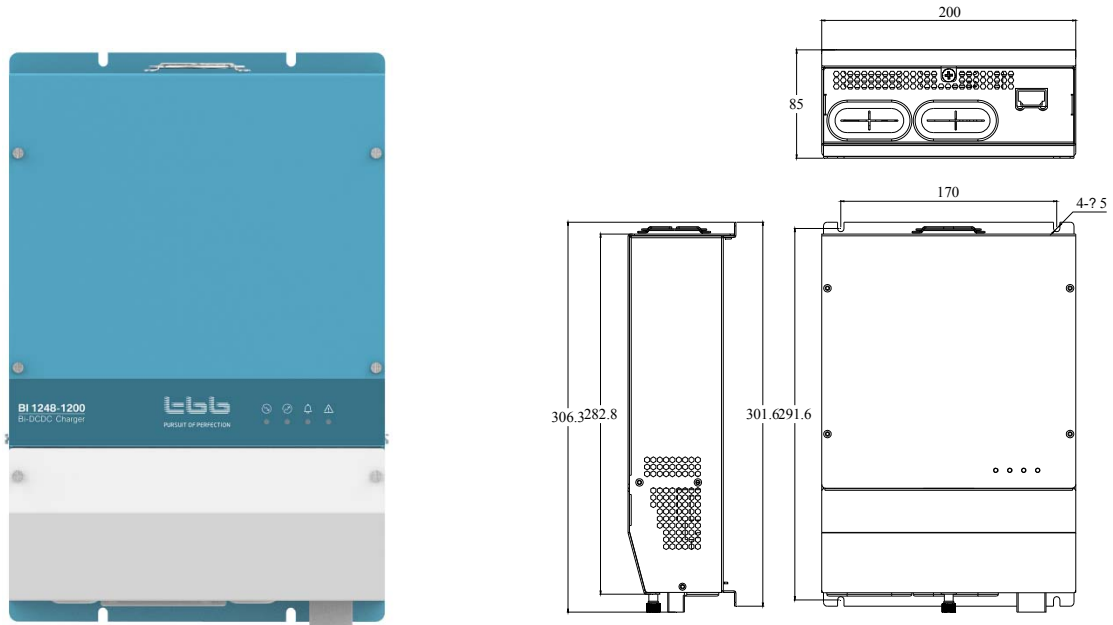

Dimension : 306.3\*200\*85mm

Weight : 3kgs



## 4. Preparation

### 4.1 Inspection

After unpacking, please check if the unit is damaged during the transportation and there is complete set of accessories.

- Users manual
- Signal wire

### 4.2 Installation requirements

- Storage temperature -40~+70°C
- Working temperature -25~+60°C,
- Relative humidity: 5%-95%, no condensation
- Cooling method: air cooling
- Altitude: 2000m or less, meeting the derating requirements of GB3859.2-93

### 4.3 Cable and Fuse preparation

Please refer to the table below for cable and fuse specifications:

Model	Connector	Nominal Current	Recommended cable	Recommended Fuse
Bi1248-1200	12V+	12Vdc 100A	length<2m, 25mm <sup>2</sup> or 3AWG and above	No extra fuse requested
	12V+and BAT-	12Vdc 200A	length<3m, 35mm <sup>2</sup> or 2AWG and above	250A
	48V+and BAT-	48Vdc 25A	10mm <sup>2</sup> or 7AWG and above	No extra fuse requested
	COM	-	22AWG	



**Please install a cable fuse on 12Vdc input as safety.**

## 5. Installation



For the user operation safety, cut off the power before installation.



Please double check that the installed battery voltage is 48Vdc

### 5.1 Installation recommendations and operations

- It is necessary to turn off the power switch or external control signal to prevent Bi1248-1200 from working due to, which may cause sparking during the wiring process.
- Please select the appropriate location with adequate ventilation to install Bi1248-1200, and fix it with M5 screws.
- In order to ensure the ventilation, please assure minimum 10cm without obstruction at both ends. And, minimum 5cm at left and right side.

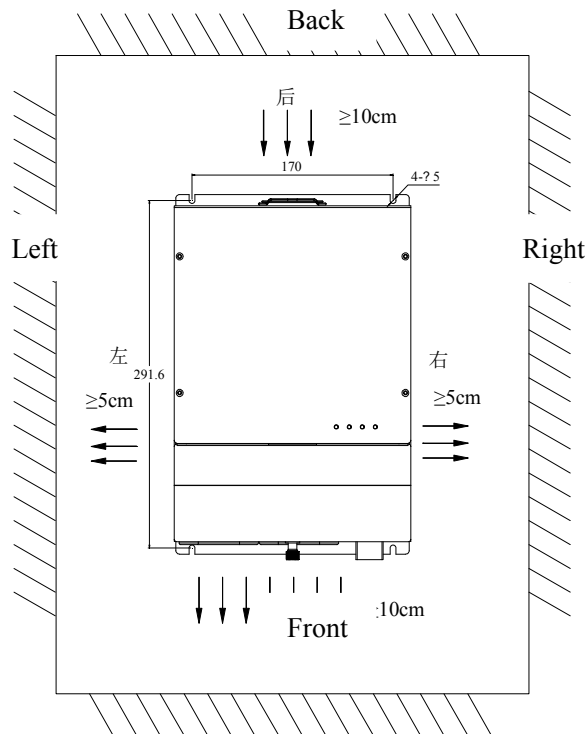

### 5.1 Wiring diagram

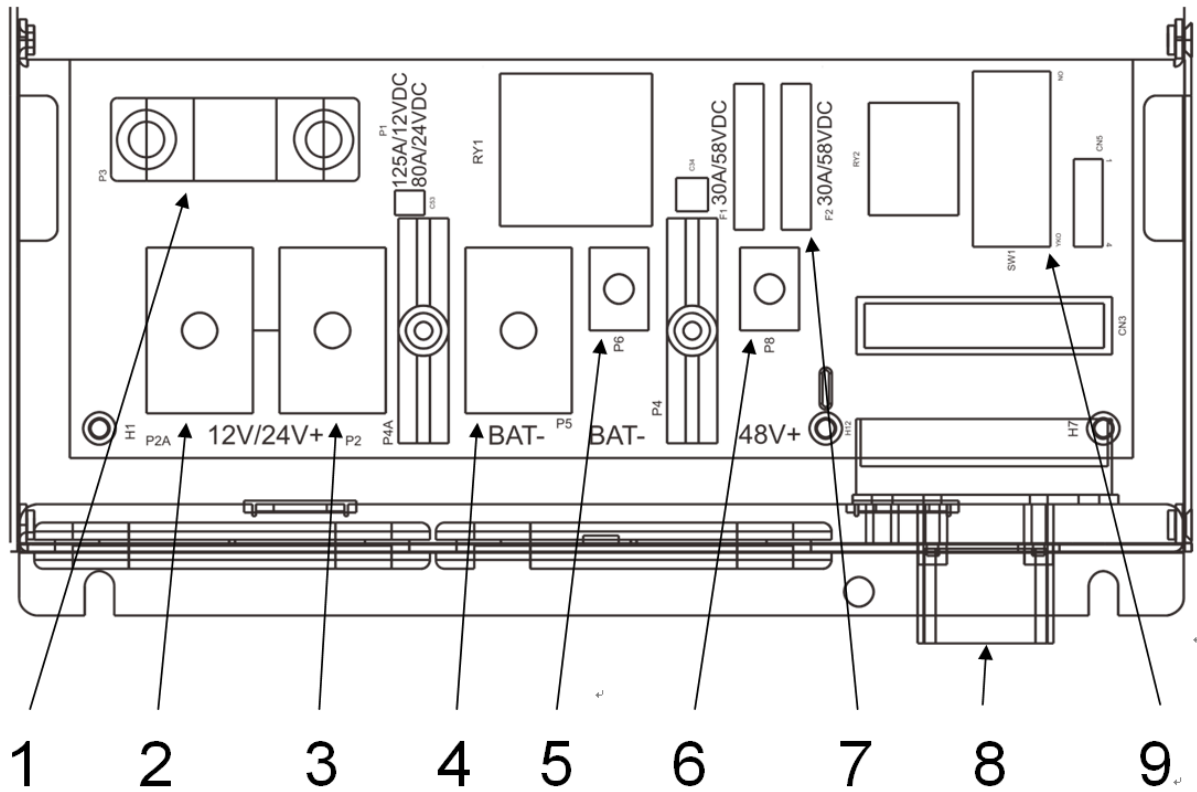

Figure 5 Schematic diagram of the key components of Bi1248-1200 wiring compartment

Table 4 Key materials specification of wiring compartment

No .	Name	Description
1	Starter battery fuse	125A/58VDC
2	+12V terminal	Positive terminal for 12V DC loads, the maximum current is 100A
3	+12V terminal	Positive terminal of starter battery, the maximum current is 200A
4	-BAT terminal	Negative terminal of starter battery, the maximum current is 100A
5	-BAT terminal	Negative terminal of auxiliary battery, the maximum current is 25A
6	+48V terminal	Positive terminal of auxiliary battery, the maximum current is 25A
7	COM	Various system signaling wire: voltage, temperature, dry contact etc.
8	DIP switch	8-digit DIP switch for Bi1248-1200 parameter setting
9	auxiliary battery fuse	2 PCS, 30A/58VDC

## 5.2 DIP switch definition

The unit wiring compartment has an 8-digit DIP switch to set up information such as battery types, stand-alone mode or system mode.

DIP switch No.		DIP switch status	Definition type
1, 2	Battery Type setting	OFF,OFF	AGM (default)
		OFF,ON	GEL
		ON,OFF	LFP
		ON,ON	OTHER
3	Alternator setting	OFF	Normal alternator
		ON	Smart generator - Euro 6
4,5	System working mode	OFF,OFF	Stand-alone mode
		ON,OFF	N/A
		OFF,ON	N/A
		ON,ON	N/A
6	Communication protocol standard	OFF	N/A
		ON	TBB standard
7,8		X,X	Reserved, no function now



For Euro 6 vehicle with smart alternator, to assure the right charging, it is important to configure the device.

## 5.2 Wiring instruction

- For the crimp terminal of the 12V cable, use the **M8** nut with a flat washer and a spring washer.
- For the crimp terminal of the 48V cable, use the **M5** nut with a flat washer and a spring washer.



**Do not operate with power on, there might be danger of short circuit, sparking etc.**



**Polarity reversing of the input and output is strictly prohibited and it is out of warranty.**



**For Euro 6 vehicle with smart alternator, to assure the right charging, it is important to configure the device and connect this unit's IGN signal line to the IGN ignition signal of vehicle installed.**

- For safety reasons, please connect the negative terminal (BAT-) first, and then connect the positive terminal 48V+ of the auxiliary battery and the positive terminal 12V+ of the starter battery respectively.
- Connect one end of the negative cable to the terminal “-BAT” of this equipment, connect the other end to the negative bar, or negative terminal of starter battery and the negative terminal of service battery. Negative bar should be connected to the chassis securely.
- Connect the terminal "+48V" to the positive terminal of the 48V service battery with the cable specified for 48Vdc.
- Connect the terminal "+12V" to the positive terminal of starter battery and alternator with the specified cable for 12Vdc.
- Connect the various sampling and communication wires, including starter battery voltage sampling, service battery voltage sampling, battery temperature sampling and dry contact signal. See following chapter for details.

### 5.3 COM terminal definition

The COM terminal is for communication signal, voltage sampling signal, and a dry contact signal. The pins are defined as follows.

*Table 5 Communication terminal definition on BI charger*

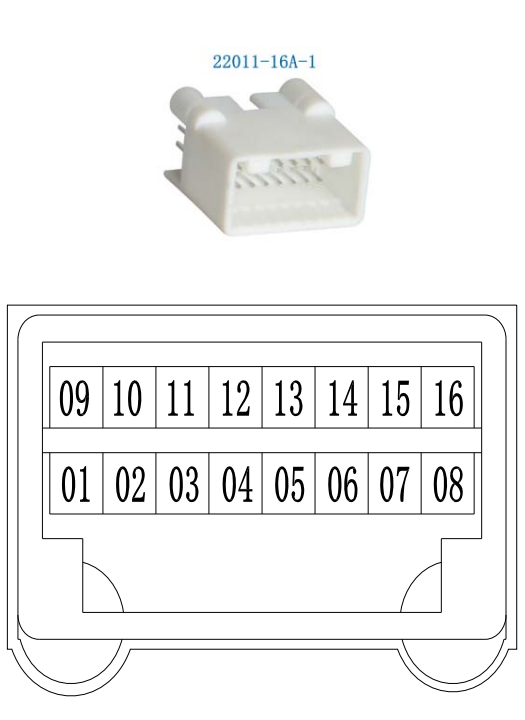
Pin No.	Function	Description	Diagram
1	IGN	Engine ignition signal	
2	VOL_BAT-	Service battery	
3	VOL_BAT+	voltage sampling line	
4	-	-	
5	RS485-A	RS485 communication signal	
6	RS485-B		
7	CAN-H	CAN communication signal	
8	CAN-L		
9	DRY_DO_NO1	Dry contact output, normally open contact	
10	DRY_DO_NO2		
11	DRY_DI_NO1	Dry contact input, normally open contact	
12	DRY_DI_NO2		
13	TEMP_BAT1	Service battery temperature sampling line	
14	TEMP_BAT1		
15	VOL_SBAT+	Starter battery voltage sampling	
16	VOL_SBAT-		

*Table 6 Wire definition on plug supplied*

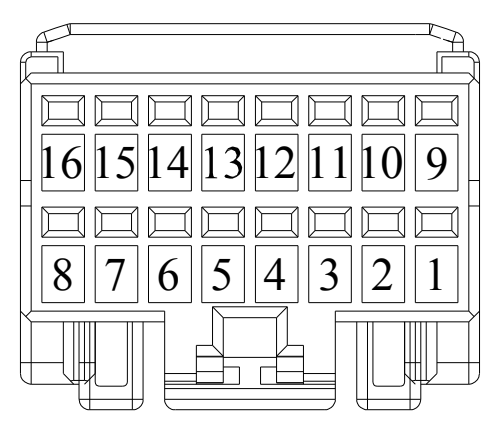
Pin No.	Wire Color	Function	Diagram
1	Black	IGN	
2	Brown	VOL_BAT-	
3	Red	VOL_BAT+	
4	-	-	
5	Orange	RS485-A	
6	Yellow	RS485-B	
7	Blue	CAN-H	
8	White	CAN-L	
9	Green	DRY_DO_NO1	
10	Grey	DRY_DO_NO2	
11	Purple	DRY_DI_NO1	
12	Black-White	DRY_DI_NO2	
13	Black-Blue	TEMP_BAT1	
14	Black-Green	TEMP_BAT1	
15	Red-Black	VOL_SBAT+	
16	Red-White	VOL_SBAT-	

## 6. Users Instructions

### 6.1 Checking and Power On

- Please double confirm the alternator voltage matching the input voltage of this device. Wrong voltage might damage the device and it is out of warranty.
- Please double check the input and output was connected correctly to starter battery and auxiliary battery correctly.
- Please double check the polarity of input and output. Reversing polarity of the input and output is strictly prohibited.
  
- Check if the voltage and temperature compensation lines have been connected to the positive terminal of service battery.
- If the generator is a smart generator, confirm that the DIP switch is in the correct position according to Table 7. Check if the IGN wire is connected to the IGN ignition signal of vehicle installed.
- Check if the unit is installed firmly.

All above checking turn on the engine and press the power button, the corresponding LED indicator lights up and the device will deliver charging to auxiliary battery.





Turning off the engine, the device will convert 48Vdc into 12Vdc to power the load connected.

## 6.2 Indicator definition



Figure 6 Bi1248-1200 indicator film diagram

Table 6 Bi1248-1200 indicator status description

Indicator Identification	Indicator Name	Color	Status Description
	Buck mode	Green	On: 48V battery is normal, 48V battery charges 12V battery Flash: standby Off: others
	Boost mode	Green	On: 12V battery is normal, 12V battery charges 48V battery Flash: standby Off: others
	Alarm	Orange	Flash: overheating of the radiator, over temperature of the battery, overvoltage of the service battery, under-voltage of the service battery, loss of communication, etc. Off: others
	Fault	Red	Flash: Starter battery overvoltage, service battery overvoltage, output short circuit, output over current, internal over temperature, internal auxiliary power abnormality, etc. Off: others



### 6.3 Auxiliary battery charging curve

➤ Charging curve

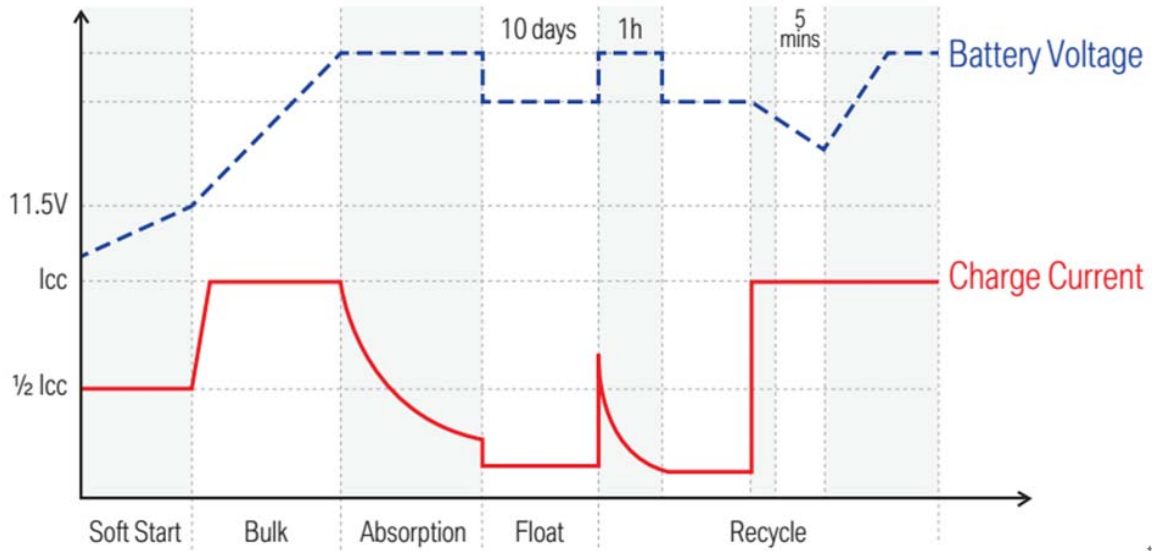

Figure 7 TBB standard battery charging curve

➤ Battery types and bulk charging & absorption charging voltage

Table 8 Service battery types and bulk charging & absorption charging voltage

No.	Battery types	Bulk charging voltage	Absorption charging voltage
1	AGM	57.6V	54V
2	GEL	56.4V	54.4V
3	LFP	57.6V	54V
4	Others	56V	54V

## 6.6 Operating temperature de-rating curve

This device has built in intelligent temperature control and will reduce its output power in case of high working temperature reached.

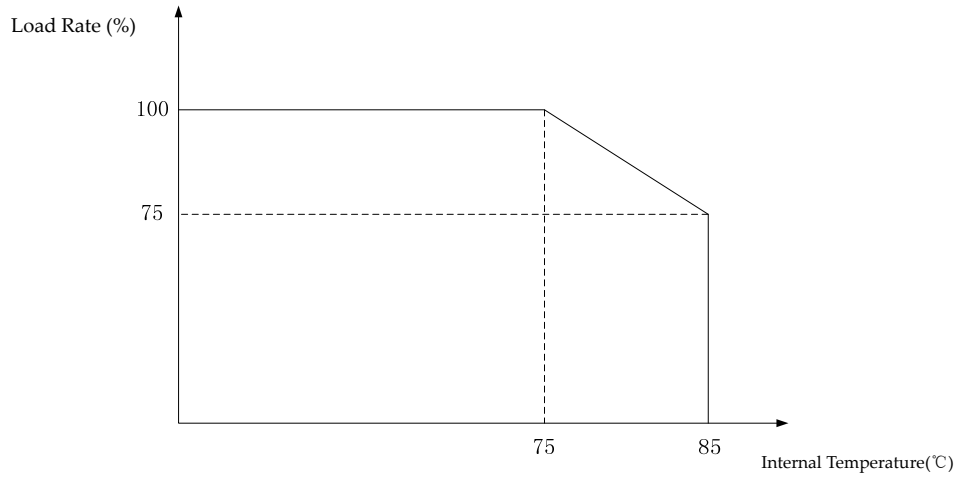

Figure 8 Bi1248-1200 internal temperature and output power derating curve

## 7. Technical Data Sheet

		<b>BI1248-1200</b>	
Working mode		Booster mode	Stepdown mode
Electrical	Input voltage	11.6~16V	42~60V
	Max Input current	100A	25A
	Output voltage	Nominal 48Vdc, adaptive charging	13Vdc
	Charging algorithm	TBB premium II multi stage	Constant Voltage
	Max Output current	25A	100A
	Efficiency	Max>94%, Full load>91%	
	Standby consumption	<2mA	
Protection	Input overvoltage	alarm: 14.9Vdc, protection: 16Vdc	alarm: 59.6V, protection: 60Vdc
	Output overvoltage	alarm: 59.6V, protection: 60Vdc	alarm: 14.9Vdc, protection: 16Vdc
	Over temperature	85°C	85°C
	Output Shortcircuit	Fuse	Software
	Electric Strength	2000V	2000V
Others	Working temp	: -25°C - 60°C	
	Cooling	Thermal control fan	
	Protection	IP20	
	Dimension	282.8 x 200 x 85mm (LxWxH)	
	Installation Size	306.3 x 200 x 85mm (LxWxH)	
	Structure	Powdered steel	
	Weight	3kgs	

**TBB Power Co., Ltd**

Web: [www.tbbpower.com](http://www.tbbpower.com)

Tel: +86-592-5212299

Fax: +86-592-5796070

Email: [service@tbbpower.com](mailto:service@tbbpower.com)